



SNO-MASTER®

WHEEL KIT

Assembly Instructions

SNO-MASTER® CHASSIS - DRAWBARS - SUB-FRAME

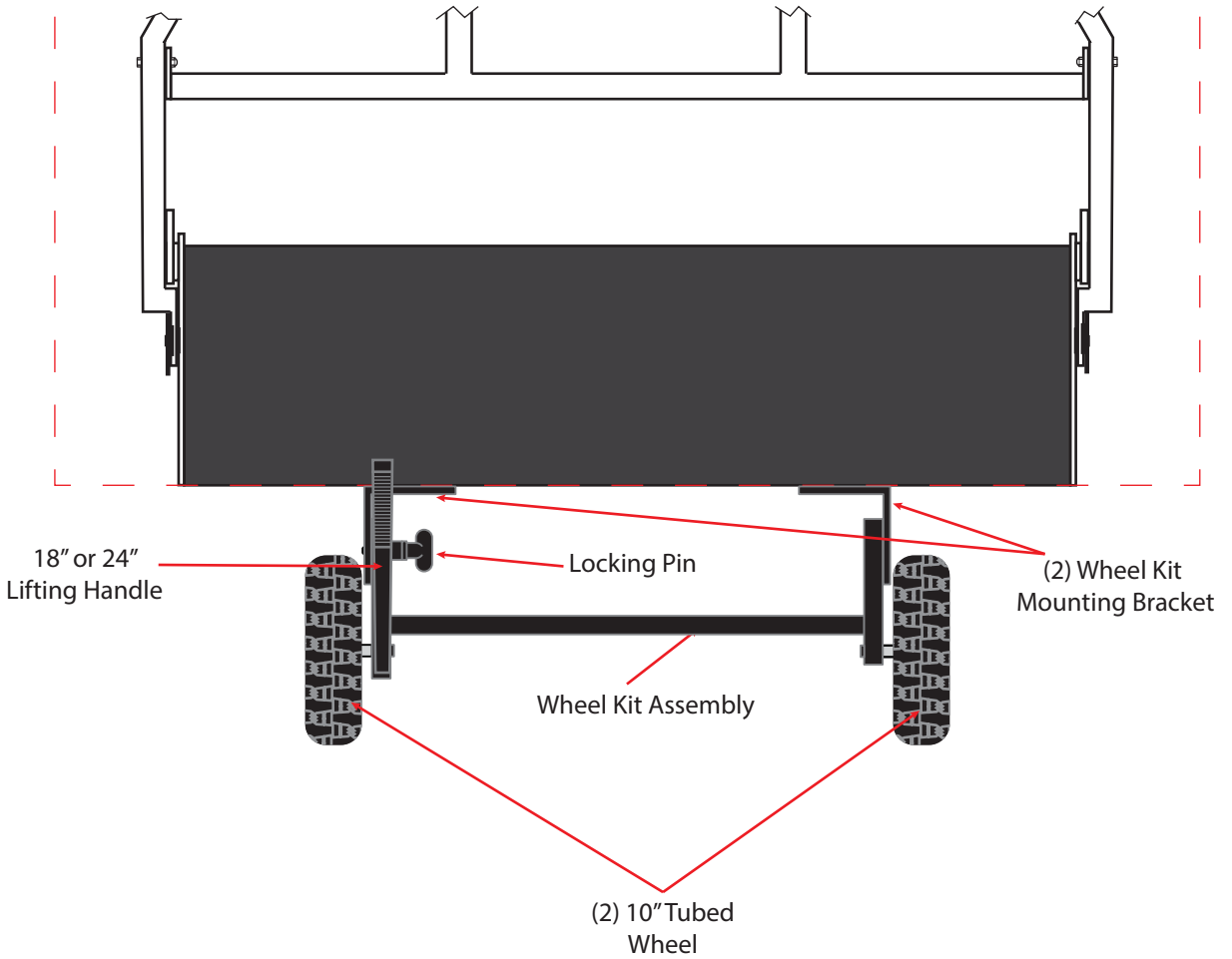

TOOLS



7/16 (11MM) WRENCH

3/4 WRENCH



7/16 (11MM) SOCKET

3/4 SOCKET

& RACHET



NEEDLE NOSE

PLIERS

PARTS & HARDWARE

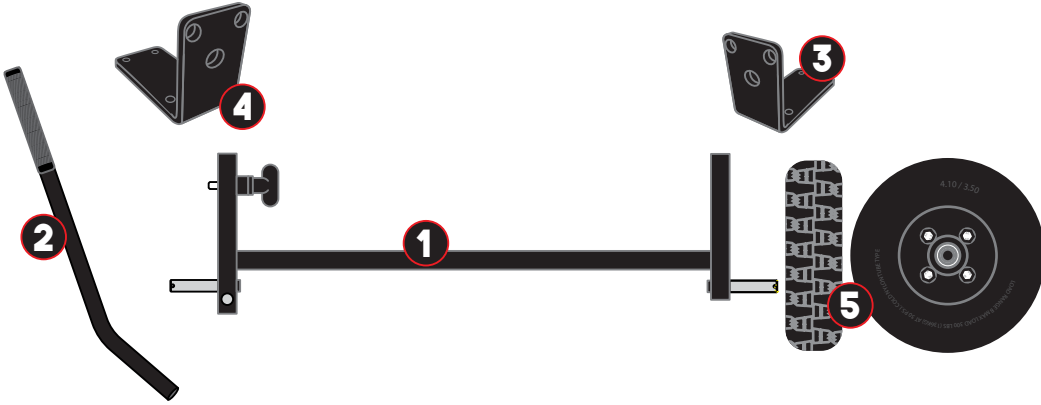

- 1** 1 - WHEEL KIT FRAME W/ AXLES & LOCKING PIN
- 2** 1 - LIFTING HANDLE
- 3** 1 - MOUNTING BRACKET (RH)
- 4** 1 - MOUNTING BRACKET (LH)
- 5** 2 - 10" TUBED WHEELS

HARDWARE

- 8 - 1/4-20 X 7/8" STAINLESS STEEL HEX BOLT
- 1 - 1/4-20 X 1-1/2" STAINLESS STEEL HEX BOLT
- 9 - 1/4-20 STAINLESS STEEL NYLOCK NUTS
- 2 - 5/8" STAINLESS STEEL WASHER
- 2 - 1/8" X 1" STAINLESS STEEL COTTER PINS
- 1 - ANTI-SEIZE PACKET

ASSEMBLY STEP 1

STEP 1: INSTALL MOUNTING BRACKETS

Open the right and left weight covers to gain access to the weight compartment of the SNO-MASTER® weight compartment. **Remove weights if previously installed.**

Remove the right and left mounting brackets from the wheel kit assembly using the 3/4" wrench and socket. Be sure to identify the left bracket and place it on the left side of the chassis. The operation of the locking pin has been adjusted specially for the left bracket.

Locate the mounting holes on the right and left of the back of the chassis. The holes are often hidden by the SNO-MASTER® label(s).

Insert the (8) 1/4-20 x 7/8" Stainless Steel Hex Bolts (4 for each bracket) from the inside of the chassis, through the bracket and finger tighten with a 1/4-20 Stainless Steel Nyloc Nut.

Before tightening, verify the wheel kit assembly will fit between the brackets.

** Multiple Holes have been pre-drilled to easily install Wheel Kits, SM Rear Hitch, or Tow Bar Brackets. **

With all 8 bolts installed and spacing verified, push the brackets to the outside edge (Left Bracket to the left, Right Bracket to the right), and tighten all 8 hex bolts.

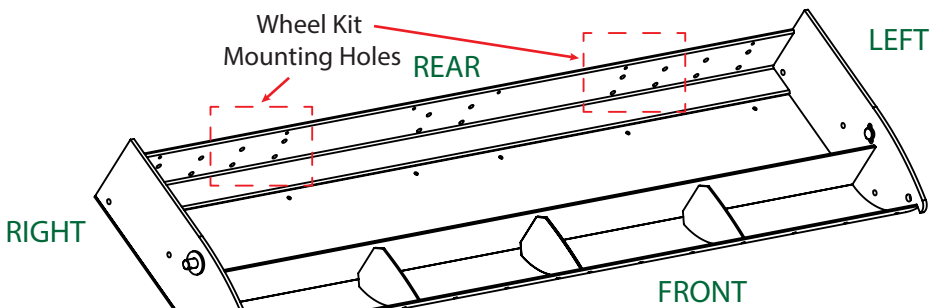

ASSEMBLY STEP 2

STEP 2: ATTACH WHEEL KIT FRAME

Place the Wheel Kit Frame inbetween the two mounting brackets so the lifting handle pin is on the left side and pointing up.

Re-insert the 1/2-13 x 2" Stainless Steel Hex Bolts that was removed to attach the mounting brackets. Insert from the inside (Center line of the chassis) through the frame, 1/2 Stainless Steel Washer (with grease), through bracket. Finger tighten the 1/2-13 Stainless Steel Nylock Nut on the exposed threads.

Repeat on opposite side.

After both are installed, tighten to take out the space between each component, but continuing to allow the frame to freely rotate.

Before proceeding, test the rotation of the frame and the locking pin alignment. Pull the pin, rotate, then release the pin and rotate to allow the locking pin to seat in the "Engaged" and "Disengaged" positions. If the locking pin does not seat properly, check the two locking position holes for burrs or paint buildup. If it needs to be cleared, use a round file to lightly remove material to allow ease of operation.

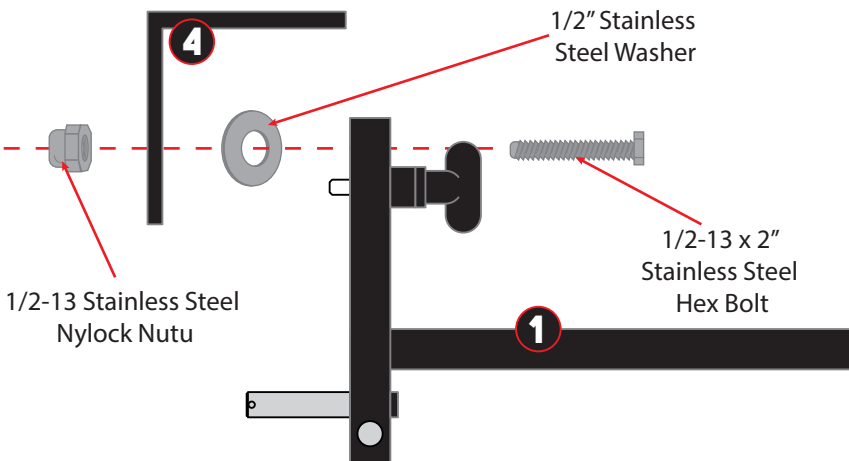

ASSEMBLY STEP 2

STEP 2: ATTACH WHEELS

Apply a thin coat of grease over the axels on each side of the Wheel Kit Frame.

Using a grease gun, pump all-purpose grease to the inside of the wheel hub, then slide the wheel on the axel.

Slide a 5/8" Stainless Steel Washer on the axel, tighten against the wheel hub. Then insert the 1/8" Cotter pin through the hole at the end of the axel.

Using the needle nose pliers, grab the slightly longer length of Cotter Pin and bend it away from the center. Grab the remaining straight portion of the Cotter Pin and bend it in the opposite direction.



Repeat on the opposite side.

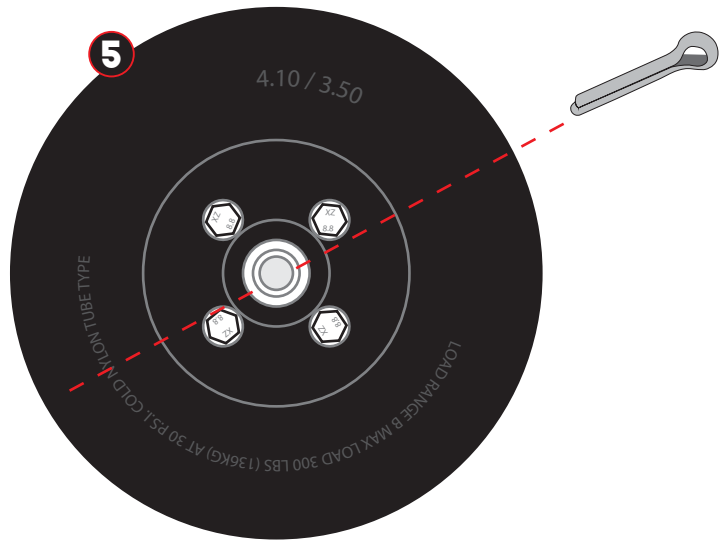

ASSEMBLY STEP 3

STEP 3: ATTACH LIFTING HANDLE

Apply a small amount of All-Purpose grease to the handle post located on the top left of the Wheel Kit Frame.

Slide the Lifting Handle down on the post and align the holes so that the handle bend is toward the SNO-MASTER® chassis.

Insert the 1/4-20 x 1-1/2" Stainless Steel Hex Bolt through the handle and handle post.

Tighten the 1/4-20 Stainless Steel Nylock Nut to secure the handle to frame.

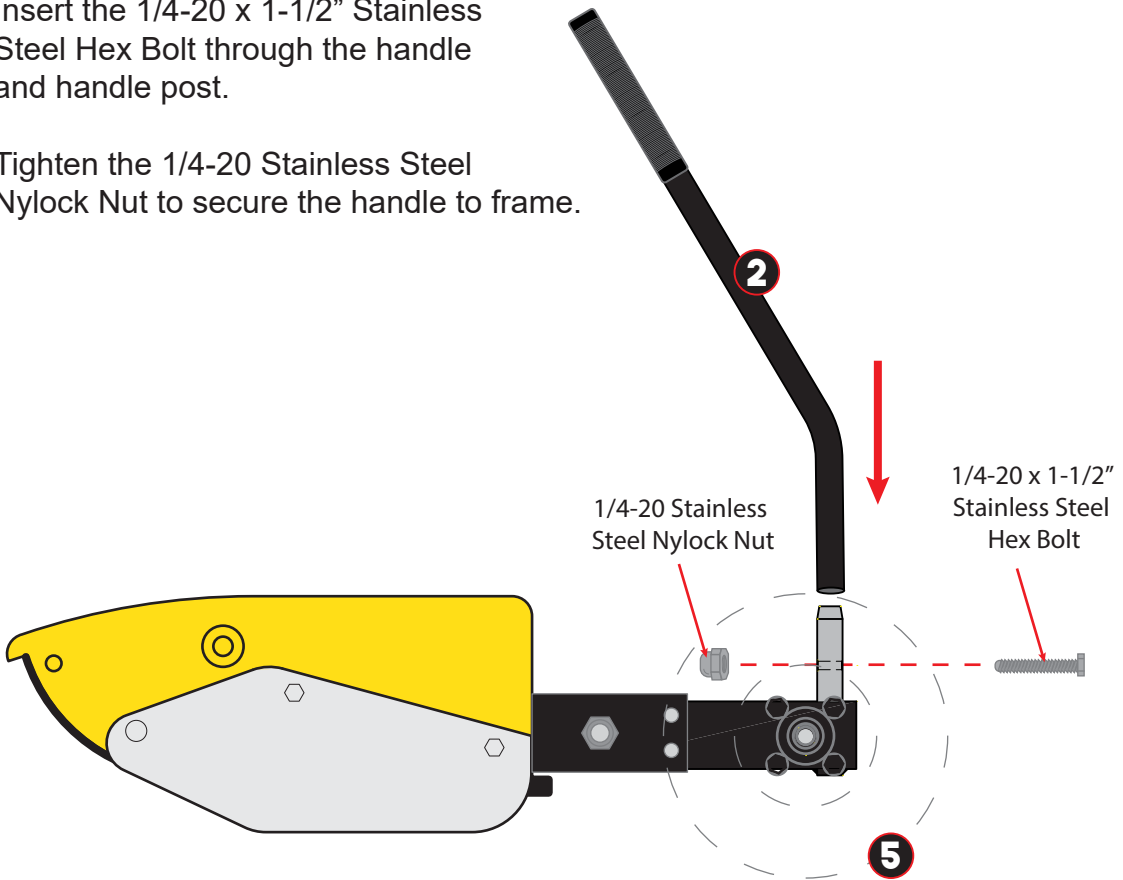

OPERATION

ENGAGE WHEELS

To engage the wheels, pull the Locking Pin T-Handle and then pull the handle back. Once the locking pin is past the the locking hole, release the pin and continue pulling the handle until the Locking Pin seats into the lower locking hole.

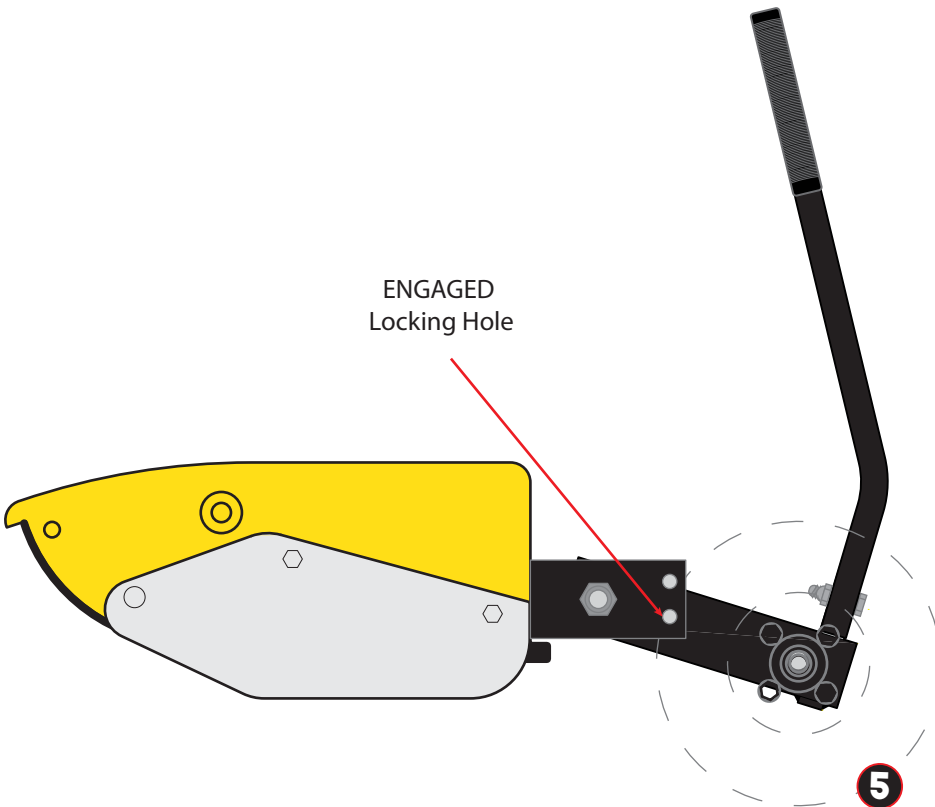

OPERATION

DISENGAGE WHEELS

To disengage the wheels, pull the Locking Pin T-Handle and then push the handle forward. Once the locking pin is past the the locking hole, release the pin and continue pushing the handle until the Locking Pin seats into the upper locking hole.

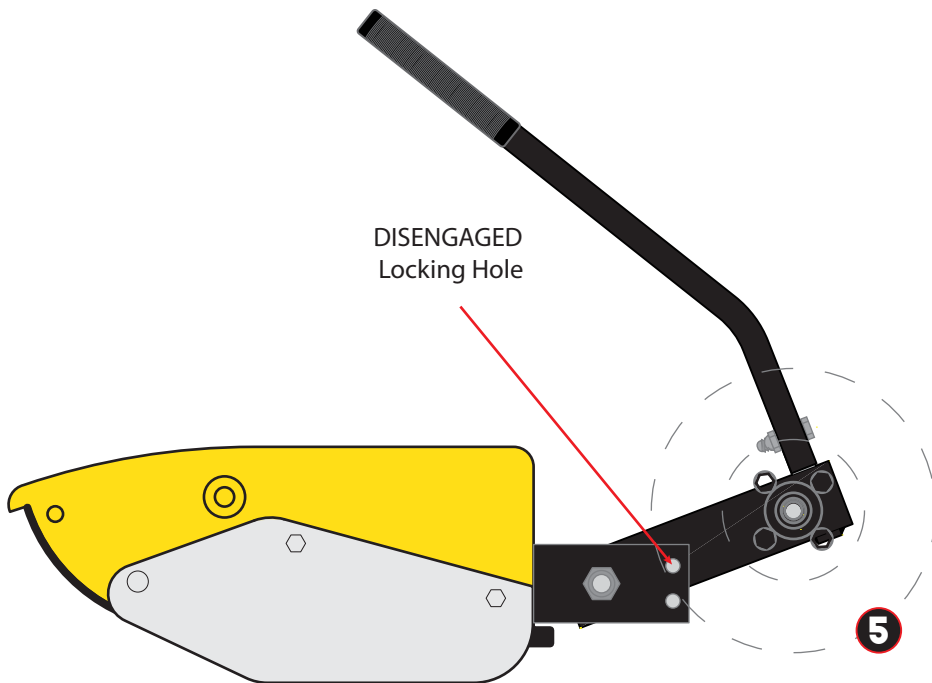

CARE & STORAGE

When storing your SNO-MASTER® snow groomer it is best to disengage the wheel kit.

Before grooming, be sure to check the tire air pressure. Tires are rated for 300lbs with 30psi when cold. ** Warning - Exceeding 30 psi can cause damage to the tube. **

Tires are NOT rated for highway use, and it is NOT recommended for extended travel use.

Regular removal of tires to add grease to the inside of the wheel hub is encouraged for extended life of the axels and wheel bearings.

USES

1. Engage to lift chassis above surface while crossing paved or gravel roads not fully covered with snow.
2. Engage prior to attempting to reverse directions to assist in turning around at the end of your grooming trail.
3. Engage to lift chassis above a paved surface to enable ease of moving chassis within garage, shop, or storage facility.

SNO-MASTER®

WHEEL KIT



FROM OUR TEAM TO YOURS, THANK YOU TRUSTING YOUR SNOW GROOMING NEEDS TO US. MANY HOURS HAVE GONE INTO MAKING AND DELIVERING HIGH QUALITY EQUIPMENT THAT IS EXPECTED TO LAST A LIFETIME. WE HOPE YOU ENJOY UTILIZING YOUR SNOW GROOMERS EQUIPMENT AS MUCH AS WE ENJOYED MAKING IT.

1180 N Mountain Springs Pkwy
Springville, UT 84663
800-430-7120

www.snowgroomers.net

