

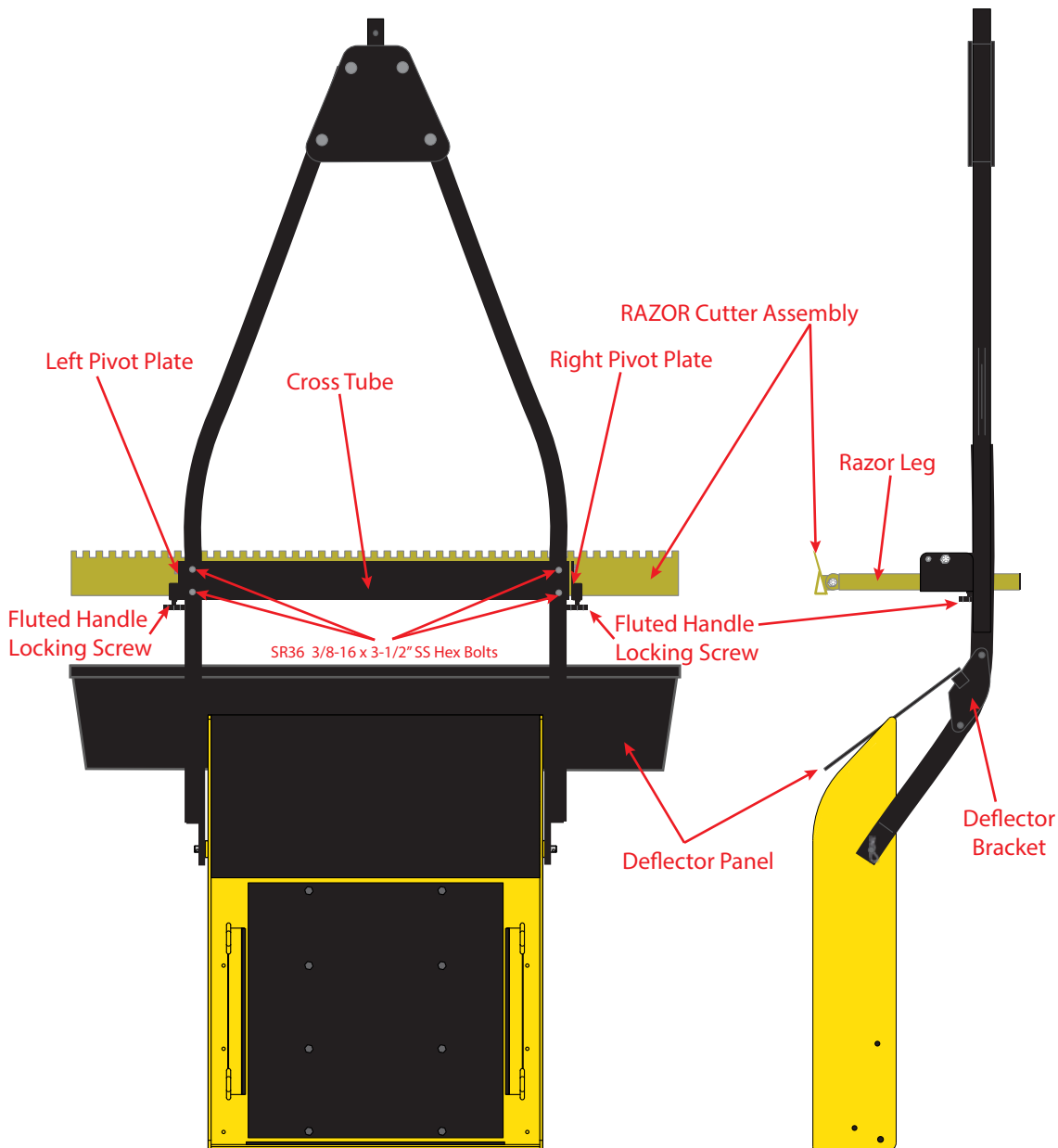

36 SNO-RAZOR[®]
Assembly Instructions



TOOLS



1/2 (13MM) WRENCH



9/16 (14MM) WRENCH



3/4 6-POINT WRENCH



**1/2 (13MM) SOCKET
9/16 (14MM) SOCKET
& RACHET**



**PHILLIPS
SCREWDRIVER**

PARTS & HARDWARE

SNO-RAZOR Assembly

- 1 - Cutter Blade Assembly
- 1 - Cross Tube
- 2 - Pivot Plates (1 Right and 1 Left)
- 2 - SNO-RAZOR Legs
- 1 - Deflector Bracket
- 1 - Black ABS Deflector Plate
- 1 - Magnetic Base Angle Indicator

SNO-RAZOR 36 Hardware

- 4 - 3/8-16 x 1-3/4" Stainless Steel Hex Bolts
- 4 - 3/8-16 Stainless Steel Nylock Nuts
- 8 - 10-32 x 3/8" Stainless Steel Truss Screws
- 4 - 3/8-16 x 3-1/2" Stainless Steel Hex Bolts
- 4 - 3/8-16 Stainless Steel Nylock Nuts
- 4 - 5/16-18 x 1-5/8" Stainless Steel Hex Bolt
- 4 - 5/16-18 Stainless Steel Nylock Nuts
- 4 - 5/16-18 x 1" Zinc Shear Bolts
- 4 - 5/16-18 Zinc Nylock Nuts

ASSEMBLY STEP 1

STEP 1: DEFLECTOR BRACKET

Loosen the nuts on the Hitch Plate, but do not remove them. Unwrap the Deflector Bracket and align the bracket plate on the outsides of the drawbars and the deflector plate attachment holes facing down. Insert the 5/16-18 x 1-5/8" Stainless Steel Hex Bolts from the outside, through the bracket plate, and then through the drawbar. Repeat until all four bracket bolts have been installed. Apply anti-seize to each of the threads, then tighten the 5/16-18 Stainless Steel nylock nuts.

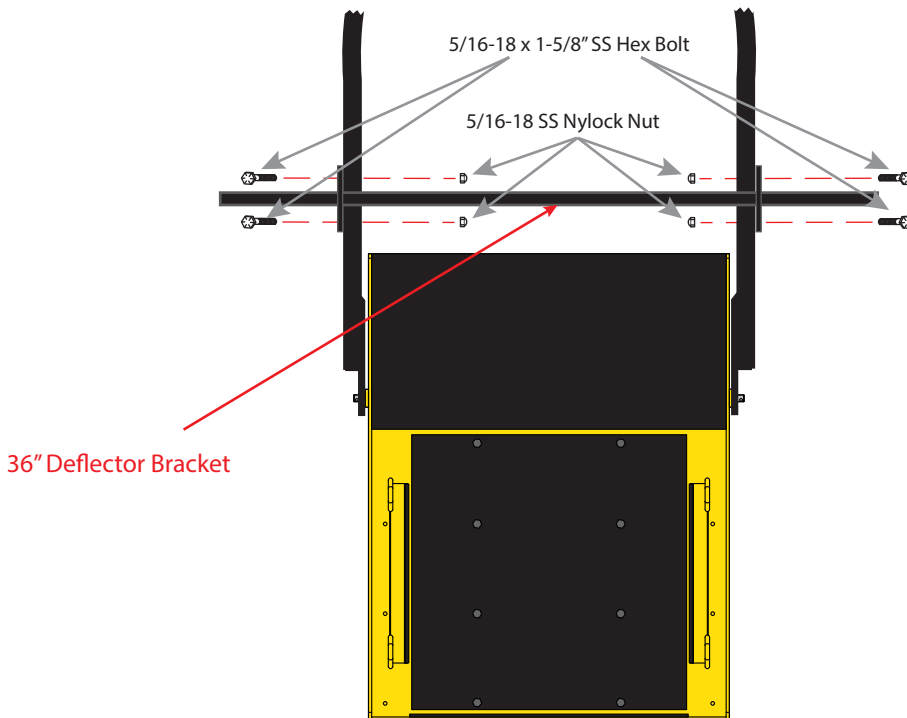

ASSEMBLY STEP 2

STEP 2: DEFLECTOR PLATE

Below the Deflector Bracket, locate the threaded mounting holes for the deflector. using a toothpick or similar, add a touch of Anti-seize to each threaded hole.

Line up the deflector plate where the holes are to the far outside edge and the textured side of the plate is facing up. Be sure to place the deflector plate in front of the chassis to properly direct the snow below the chassis.

Insert the 10-32 truss screws but do not tighten until all screws are in. with all screws threaded in the bracket, begin to tighten all the screws starting from one side and working to the other.

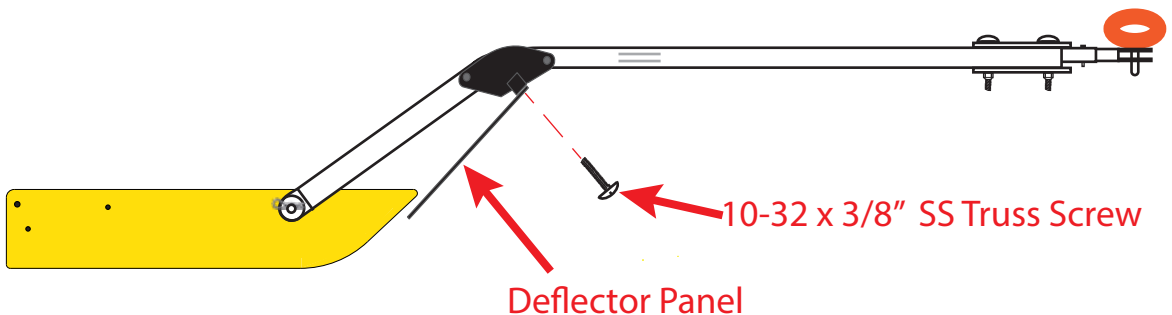

ASSEMBLY STEP 3

STEP 3: SNO-RAZOR® ASSEMBLY

Apply anti-seize to the threads on both Fluted Handle Locking Screw threads. Insert and tighten the Fluted Handle Locking Screws to hold the legs and razor cutter assembly in place.

Move the assembly below the drawbars with the Fluted Handle Locking Screws in the rear and the notched side of the cutter blade facing forward (toward the hitch plate).

Align the 4 holes in the drawbars to the 4 holes in the SNO-RAZOR® cross tube. insert the (4) 3/8-16 Stainless steel Hex bolts down through the drawbar, then through the cross tube. loosely tighten the 3/8-16 Stainless steel nylock nuts on each. Once all four are in place, tighten to approximately 12 ft-lbs.

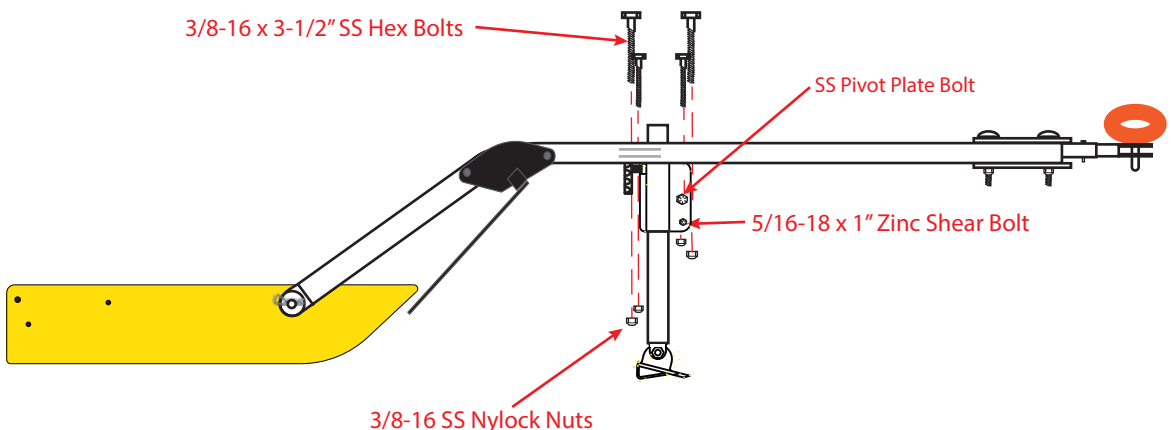

ASSEMBLY STEP 4

STEP 4: CUTTER BLADE ANGLE

Loosen the two Cutter Assembly Bolts at the bottom of the SNO-RAZOR® legs. Place the Magnetic Base Angle Indicator in the center of the cutter assembly facing left or right at a 90 degree angle of the cutter assembly.

Rotate the cutter assembly to an angle appropriate to your snow conditions. For soft or fresh snow adjust to between 18 and 20 degrees. Increase the angle the more dense or hard packed the snow conditions with a maximum angle being 30 degrees. Retighten the cutter assembly bolts to a torque of 70 ft-lbs.

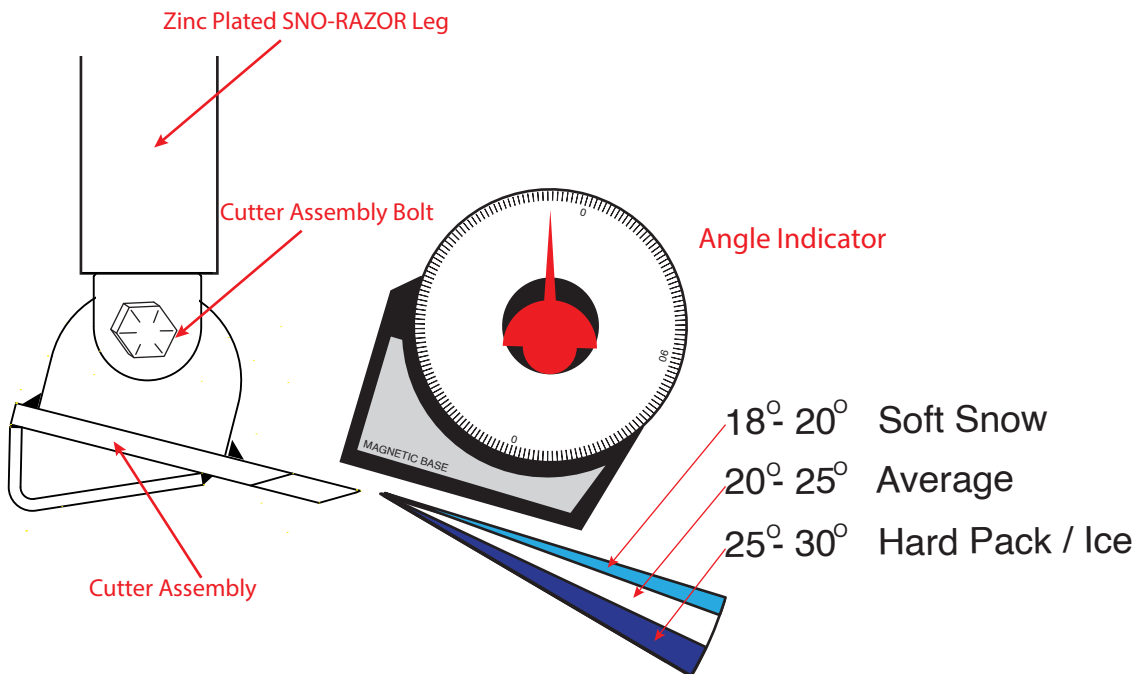

ASSEMBLY STEP 5

STEP 5: CUTTING EDGE HEIGHT

To raise or lower the cutter assembly, loosen the Fluted Handle Locking Screw at the rear of the pivot plates. Raise or lower the cutting assembly where the cutting edge of the blade is approximately 1 inch above the ungroomed surface.

Retighten the Fluted Handle Locking Screws so that vibrations will not allow the assembly to slide up or down. Groom a short distance and adjust as necessary.

It is not advised to lower more than 1/2" at a time. It is important to take into account the suspension travel of your towing vehicle when setting the starting point of 1" above the surface.

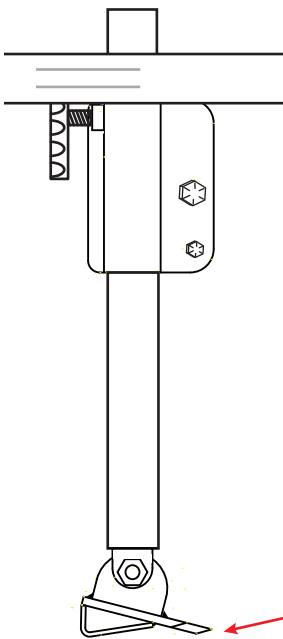

Start with cutter edge 1"
above ungroomed surface.

The target height is where the cutting edge should be level with the eventual groomed surface. If the wings are not touching or grooming the snow on the outer edge of the groomed path the razor is too low or more weight is required in the chassis.

ASSEMBLY STEP 6

STEP 6: MAINTENANCE & STORAGE

The precision SNO-RAZOR® will last many years with proper care. It should be cleaned and a light coat of oil applied to all surfaces and stored inside during the off season. Treat the SNO-RAZOR® like a fine knife, a rusty SNO-RAZOR® will not perform well.

The pivot plate bolts should be snug, but not tight, to allow the SNO-RAZOR® to swing up if it hits a hidden obstacle. Recheck the SNO-RAZOR® angle any time you shear a bolt. There are four extra shear bolts in your hardware box. Do not use any bolt harder than a Grade 2, (standard hardware grade) or damage to the SNO-RAZOR®, groomer or snowmobile can occur.

Before using your groomer each season, remove the shear bolts and make sure the SNO-RAZOR® swings up freely. Apply a film of grease to the mating surfaces of the pivot plates and Replace the shear bolts. Remove the breakaway coupler from the Hitchplate receiver and coat the coupler shaft with a film of grease and replace the shear pin.

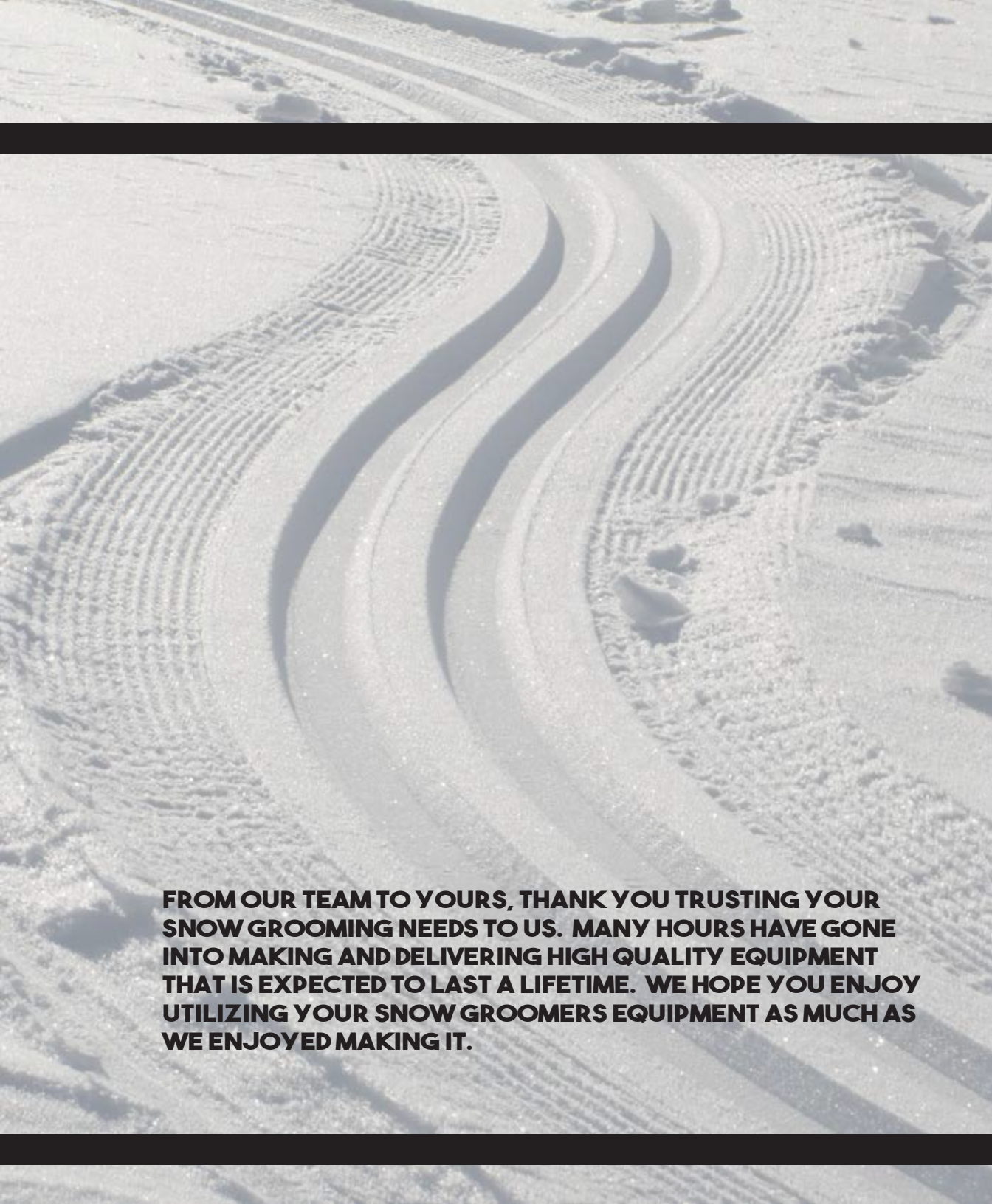
An aerial photograph of a snow-covered road. The road is marked with distinct, wavy, parallel tracks from a snow groomer, creating a rhythmic pattern across the white surface. The tracks are deep and well-defined, showing the path of the machine as it moves along the road. The surrounding snow is relatively smooth but shows some minor footprints and smaller tracks.

FROM OUR TEAM TO YOURS, THANK YOU TRUSTING YOUR SNOW GROOMING NEEDS TO US. MANY HOURS HAVE GONE INTO MAKING AND DELIVERING HIGH QUALITY EQUIPMENT THAT IS EXPECTED TO LAST A LIFETIME. WE HOPE YOU ENJOY UTILIZING YOUR SNOW GROOMERS EQUIPMENT AS MUCH AS WE ENJOYED MAKING IT.

36 SNO-RAZOR®



1180 N Mountain Springs Pkwy
Springville, UT 84663
800-430-7120
www.snowgroomers.net

